

www.XPOLE.com |     



Instruction Manual

**Please Read Fully
Before Installation**

CRITICAL INFORMATION - PLEASE READ THIS BEFORE OPENING YOUR PACKAGE

To get the best from your A-FRAME – with SAFETY being the utmost priority – it is extremely important that you READ & FOLLOW the Instruction Manual from beginning to end and most importantly, understand it!

Follow the simple but explicit instructions in this manual to get the best results from your A-FRAME.

Safety is a priority at all times.

If you have ANY questions – before you assemble, install or use your A-FRAME – contact your point of purchase or see the support/FAQ's section on the X-POLE website for your region. www.xpole.com

VERTICAL LEISURE Ltd., X-POLE INTERNATIONAL, X-POLE US INC, THEIR DISTRIBUTORS, SALES PERSONS OR ANY OTHER PERSONS OR ASSOCIATED COMPANIES CANNOT BE HELD RESPONSIBLE FOR ANY DAMAGE TO PROPERTY OR INJURY TO PERSONS OR THIRD PARTIES DURING THE USE OF THIS PRODUCT.

BY REMOVING THE A-FRAME FROM ITS PACKAGING AND/OR ANY USE OF THE PRODUCT CONFIRMS ACCEPTANCE OF THE ABOVE WARNINGS AND THE USER'S RESPONSIBILITY IN USING THE PRODUCT.

IF YOU DO NOT ACCEPT THE TERMS SET OUT ABOVE THEN:

DO NOT REMOVE THE A-FRAME FROM ITS PACKAGING OR ATTEMPT TO ASSEMBLE, INSTALL OR USE THE PRODUCT.

Contact your point of purchase to arrange a return & refund (shipping costs may still apply). The product must be returned unused & in its fully packaged state.



CAUTION: Take note that uneven floors can affect the stability of this product.



CAUTION: Never undo any of the screws unless you are explicitly told to do so in the instruction manual.



CAUTION: Never leave outside, store in a cool dry place.

Welcome

“ Thank you for buying an X-Pole A-FRAME. The team at X-POLE have spent a significant amount of time researching, designing and developing the A-FRAME. We want the A-FRAME to be a market leading piece of Aerial Apparatus, if it's not; we want to understand why not! At X-POLE we thrive on positive criticism and suggestions! So contact us (details on the back cover) if you have any comments or suggestions on how to improve the product. ”

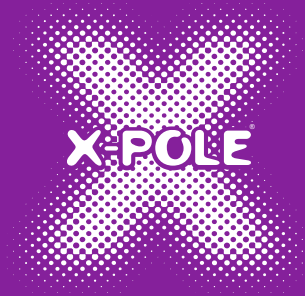

Before using your A-Frame

Mis-using the A-FRAME can be dangerous, not only to the user but also to property and anyone close to the A-FRAME. The use of an A-FRAME is always at the user's discretion, and it is the user's responsibility to check the A-FRAME is assembled correctly & safely before use. It is suggested that the A-Frame is used in conjunction with a safety mat.

Aerial exercise is extremely physical and uses muscles that you may not have used before and therefore if you are not warmed up; muscle damage, strains and injury can occur. Before using the A-FRAME it is important to warm up before use and cool down after use.

It is highly recommended that before you use your A-FRAME you attend classes to learn the basic moves. Never try moves beyond your ability without an instructor. If at any time whilst using your A-FRAME you feel uncomfortable, your muscles hurt, or you are short of breath – take a break.

Always rest between moves & exercise sensibly, if you experience any health issues, seek medical advice.

Have fun with your A-FRAME. The X-POLE Team.

The Product

X-Pole's new Aerial A-Frame is perfect for Aerial Fitness, Yoga, Aerial Hoop/Lyra, Hammock, Silks, Static Trapeze & Suspension Training. The A-Frame can be used from 2255mm (xx.xx") up to 3480mm (137.00") with multiple heights being selectable in-between.

Adjustable/Multiple Heights using the telescopic legs – can be used indoors or outdoors. Always store in a cool dry place.

Quick Assembly – all pieces can be stored safely in multi-piece bags.

Multi-discipline – swap between different apparatus such as silks, (static) trapeze, hammock, hoop & suspension training.

Portability – Light-weight frame allows the user to transport easily!

Fig. (1.1)

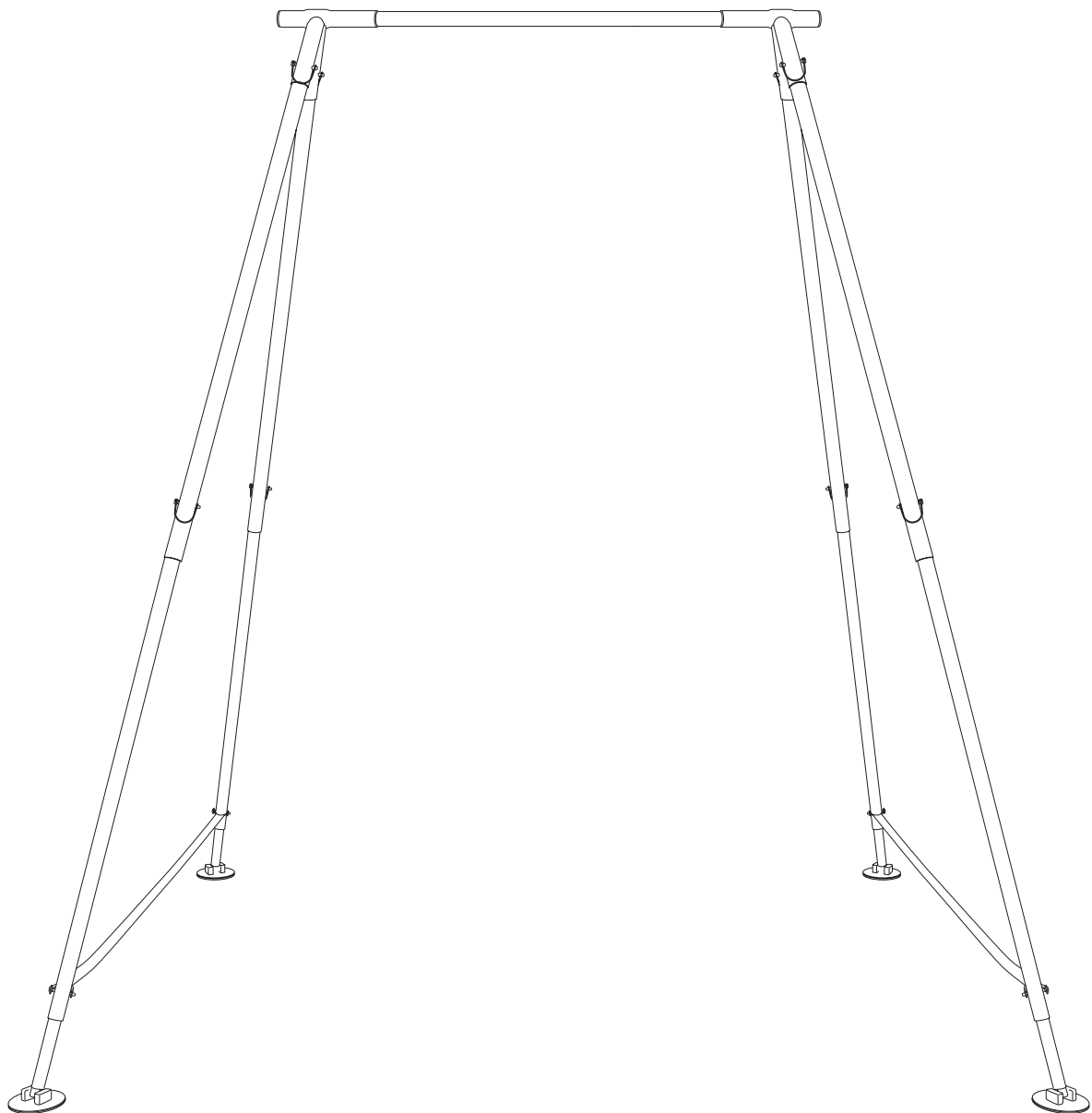

A-Frame Footprint/Build Dimensions

Fig. (2.1)

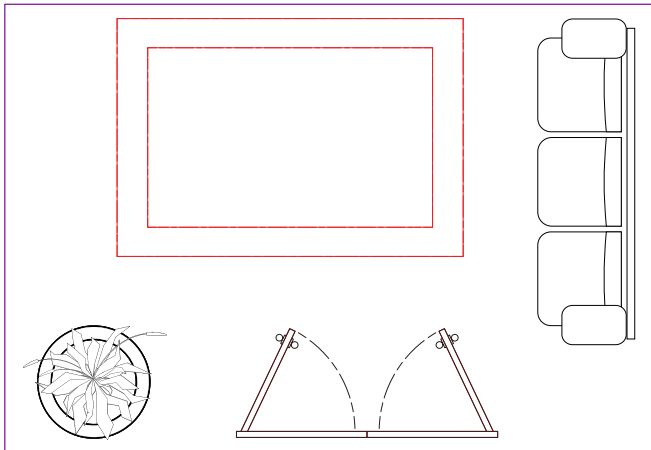

When the A-FRAME is at its lowest height, it will require a floor area of 3.6 Sq.M (38 Sq.Ft) and when fully extended will require an area of 8.9 Sq.M (95 sq-ft).

Fig. (2.2)

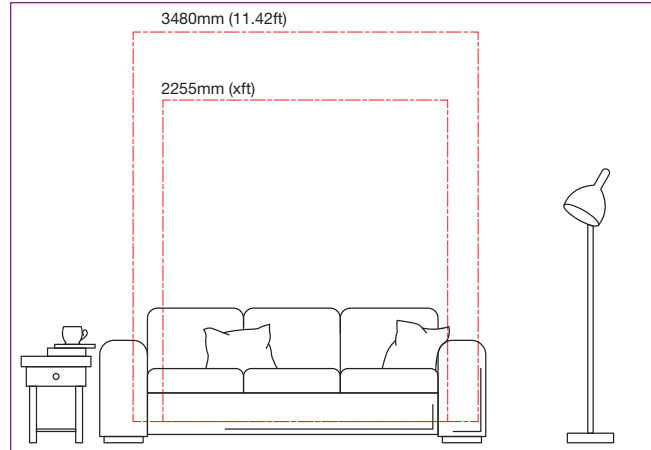

The A-FRAME could be extended from its lowest height of 2255mm (88.78 Inches) to a height of 3480mm (137.00 Inches) when fully expanded.

Height (mm)	(Inches)	Depth (mm)	(Inches)	Width (mm)	(Inches)	Sq. M	Sq. Ft
2255	88.78	1715	67.52	2080	81.89	3.6	38
2320	91.34	1790	70.47	2165	85.24	3.9	42
2390	94.09	1910	75.20	2190	86.22	4.2	45
2450	96.45	1955	76.96	2245	88.38	4.4	47
2530	99.60	2019	79.48	2318	91.25	4.7	50
2610	102.75	2083	82.00	2392	94.17	5	53
2755	108.46	2198	86.53	2524	99.37	5.5	59
2900	114.17	2314	91.10	2647	104.21	6.1	65
3045	119.88	2430	95.66	2790	109.84	6.8	73
3190	125.59	2545	100.19	2923	115.07	7.4	79
3335	131.29	2661	104.76	3056	120.31	8.1	87
3480	137.00	2777	109.33	3189	125.55	8.9	95

Measurement Key (To the top of the bar.)

Height - Measuring vertically from the floor to the top of the bar.

Depth - Measuring between the triangle (Side Profile)

Width - Measuring between the front/back legs (Front/Back Profile)

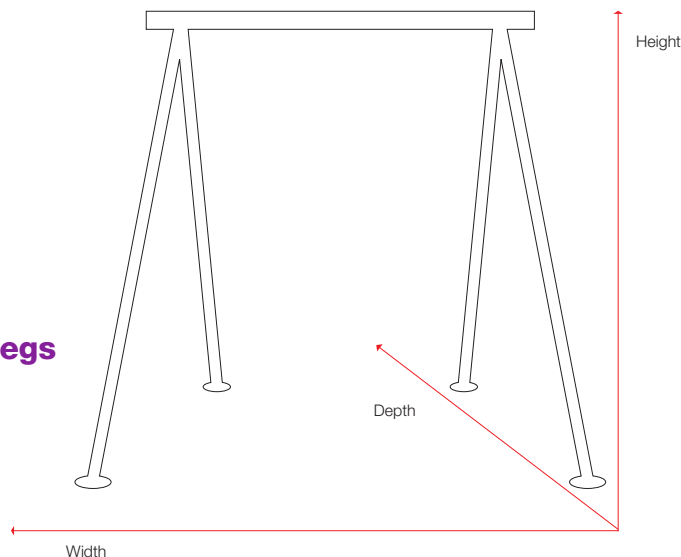

Contents

Fig. (3.1)

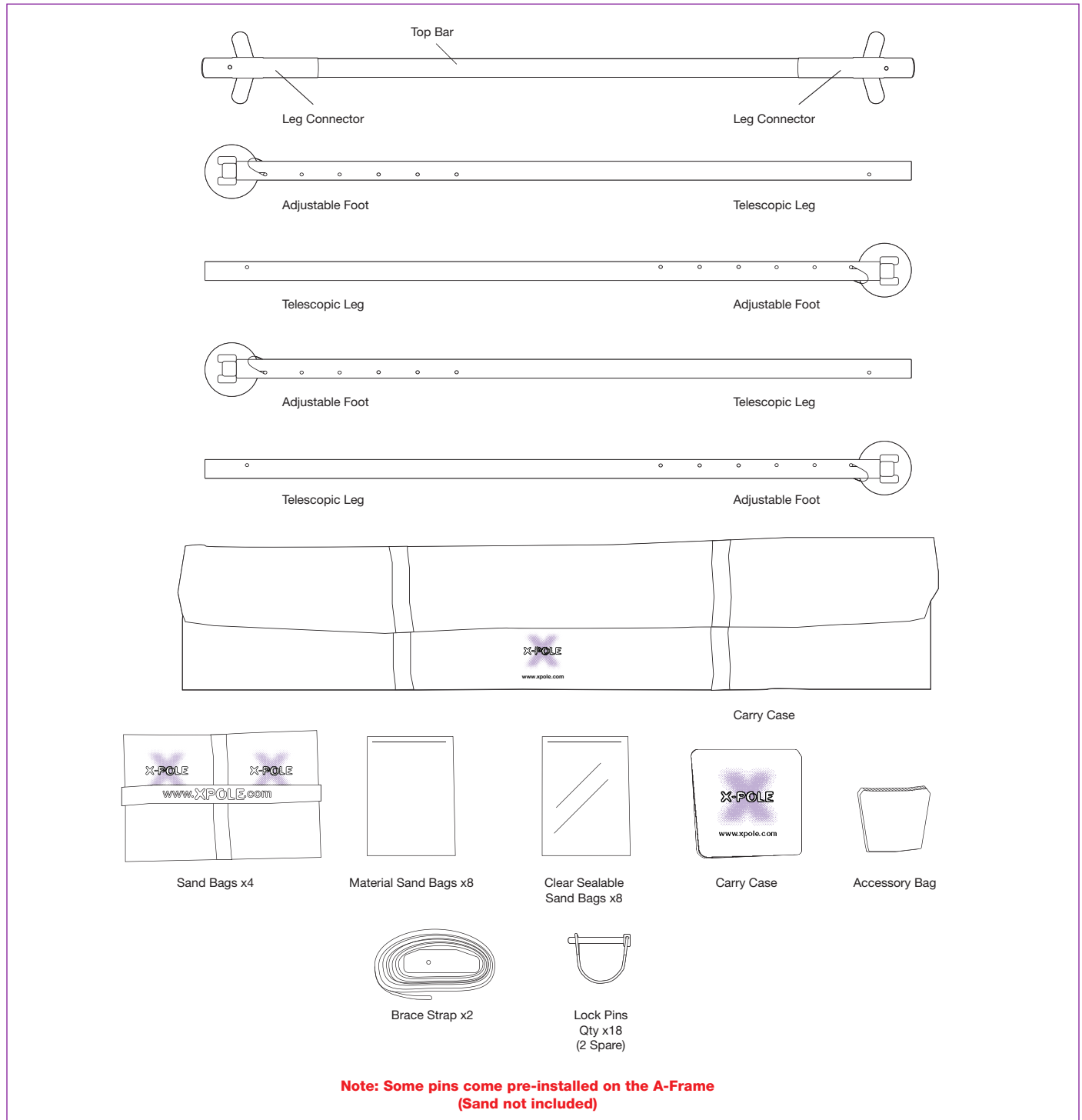

Checking The Parts

Please check the contents of your A-FRAME with the contents (Fig 3.1) If anything is missing or damaged, please contact your point of purchase or call your local X-POLE office immediately (contact details on the back page).

Please study the contents and the part descriptions in the diagram as these are used throughout the instruction manual and are important for installation. Please also try using the parts before assembling, it is important that you understand how they work. Remove the parts and place them in the space where assembly will take place.

Removing The Packaging

The A-FRAME is packaged in a special way to protect all the parts from any damage during transit. First the A-Frame needs to be lifted out of the box. It is very important to remove all the packaging prior to commencing installation. To remove foam on the top bar, you must first remove the Leg Connector. Push pin when removing - take out triangular section, remove foam then replace. Make sure pin engages securely (please refer to figure: 4.2). Whilst unpacking the items, please make sure you follow the Contents Diagram.

Fig. (4.1)

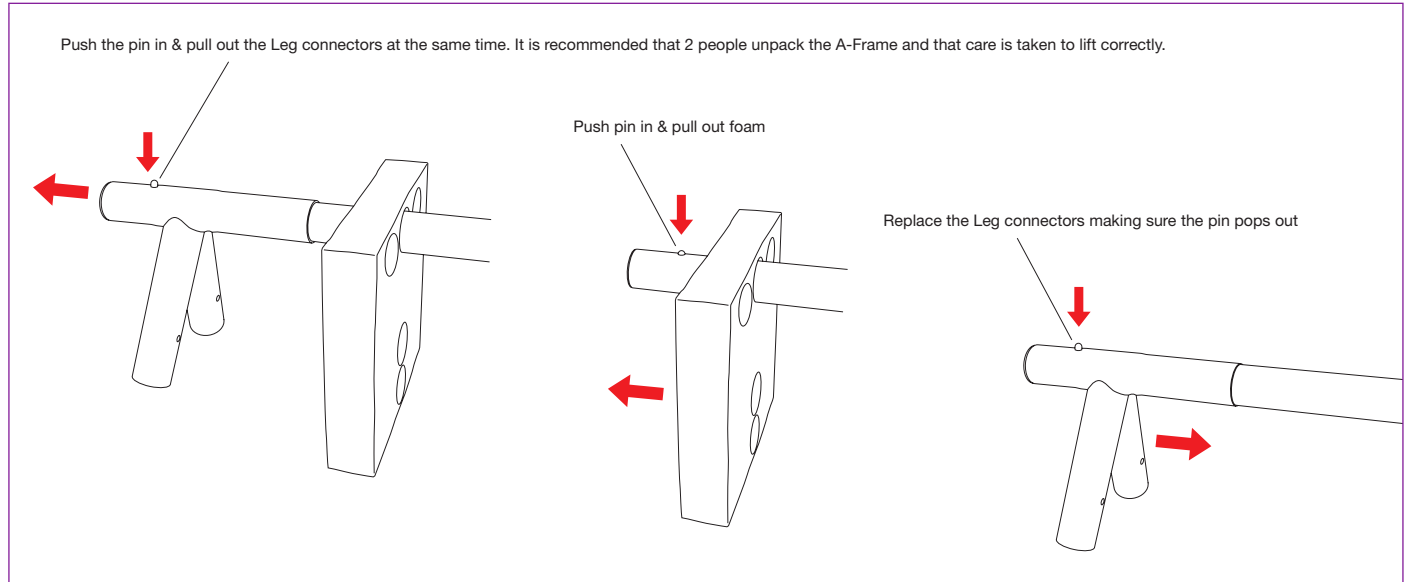

Pins

Fig. (4.2)

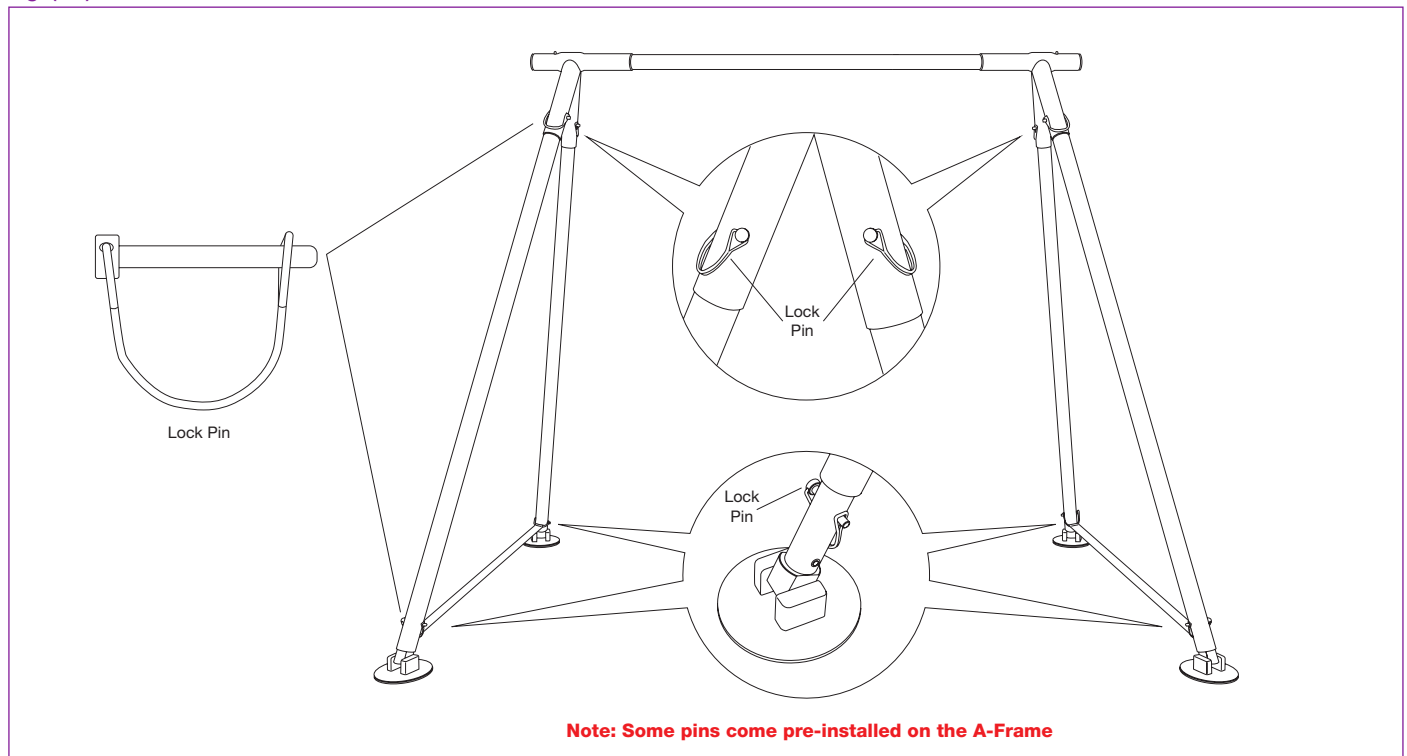

Attachment Of Legs

Fig. (5.1)

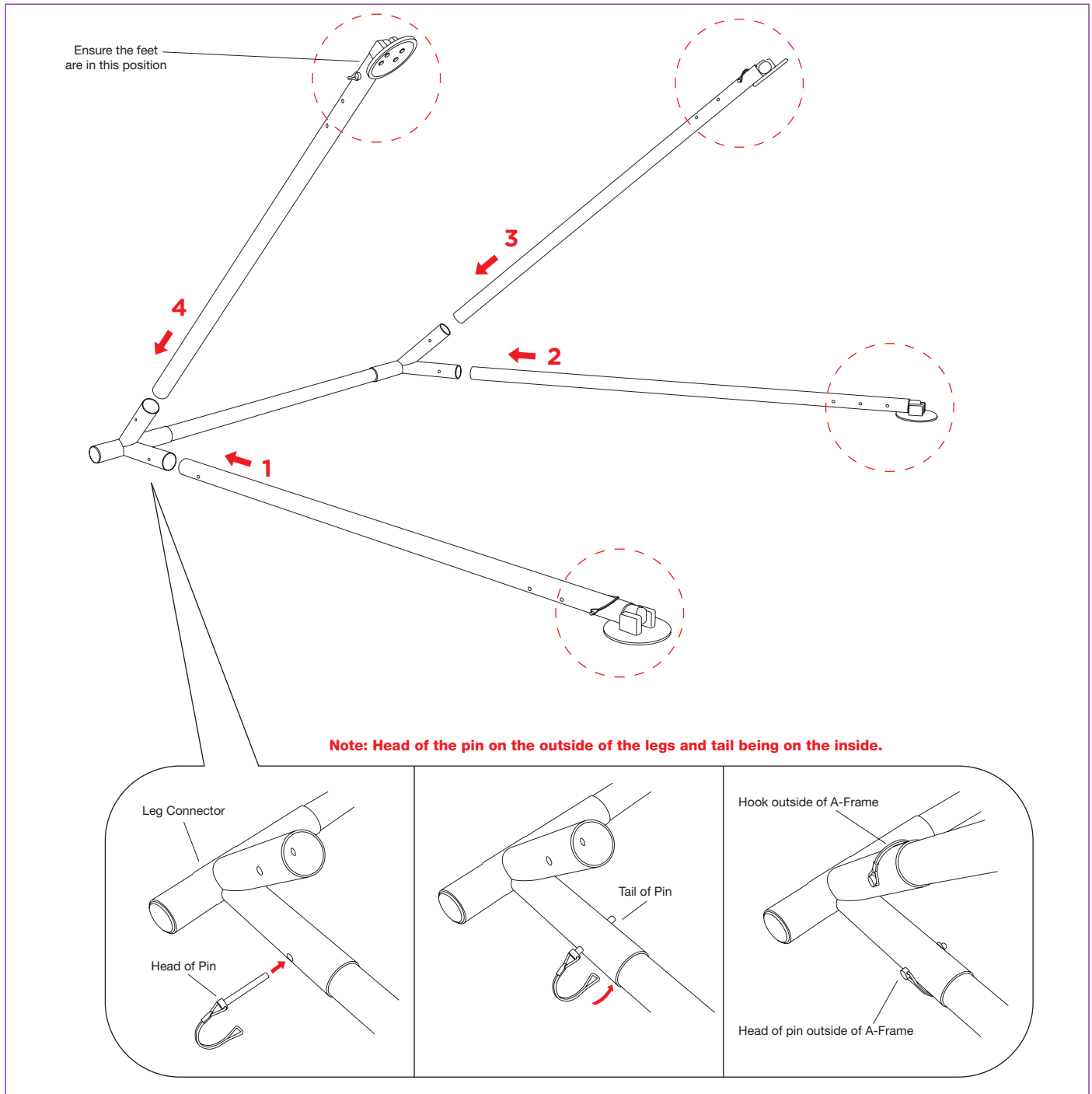

1. Lay the top bar on the ground as illustrated above.

2. Insert the leg starting with the hole at the bottom in the Leg Connector. Place the leg into the Leg Connector and line up the holes on the legs with the holes in the Leg Connector. There will be a 'guide' line etched on the legs to help with this process.

3. Once the leg has been fully inserted, secure it using the lock pin.

4. Once the first leg is secure, now repeat the process in the order illustrated in the diagram – following numbers 1 to 4.

Lifting The A-Frame

Fig. (6.1)

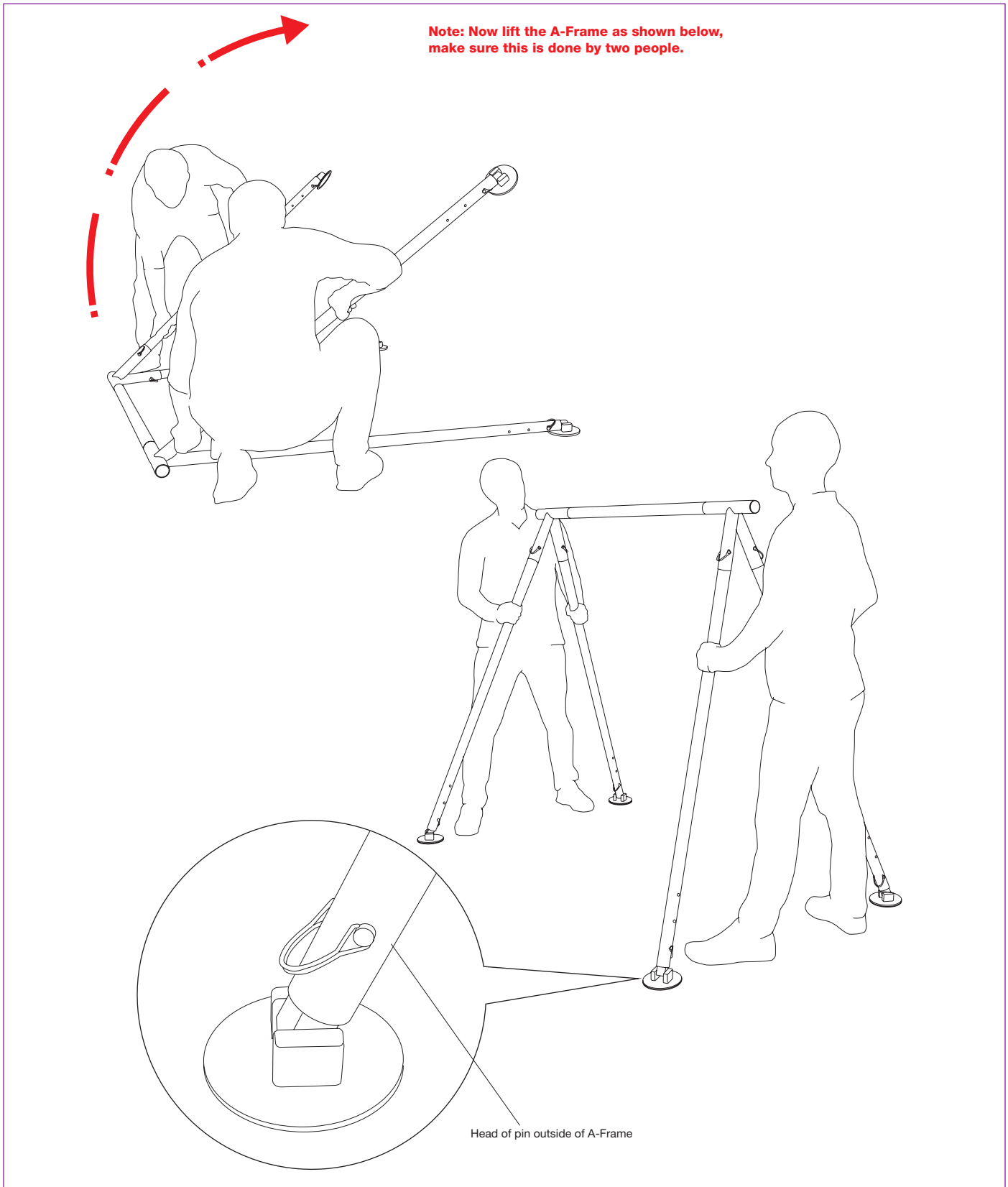

As the A-FRAME will be assembled on the floor and then lifted into position, it is important to allow enough space to do so. When lifted into position, make sure the feet are flat, by gently shaking the 2 legs each person is holding and slowly pulling outwards.

Various Rigging Options

Fig. (7.1)

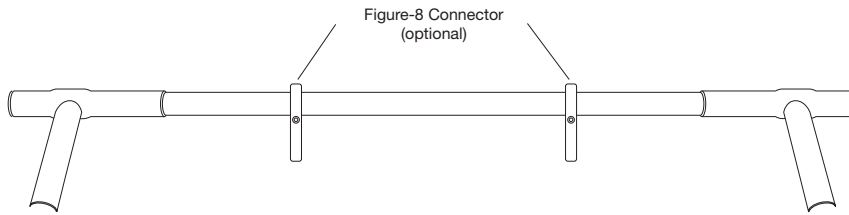

***Figure 8 connector available from your local X-Pole dealer or point of purchase.**

Fig. (7.2)

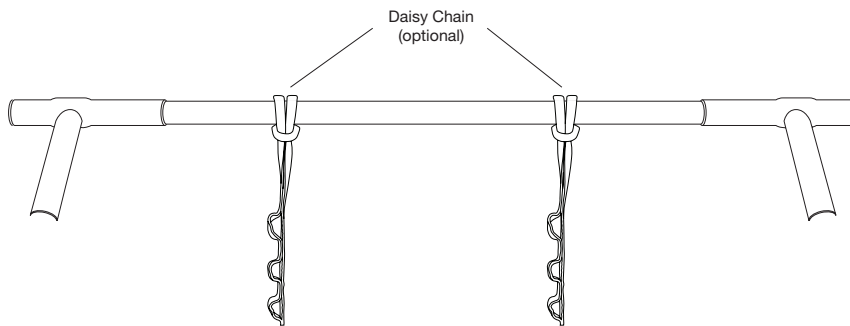

***Daisy Chain available from your local X-Pole dealer or point of purchase.**

Fig. (7.3)

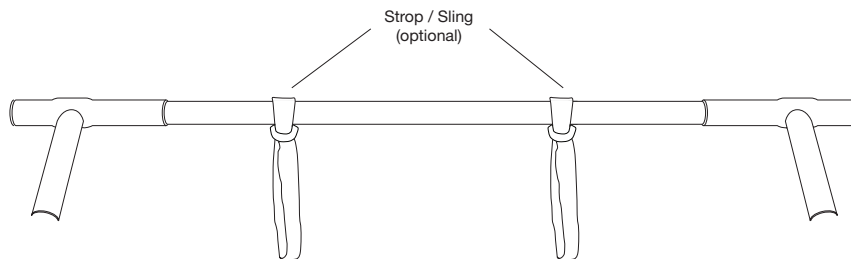

***Strop / Sling available from your local X-Pole dealer or point of purchase.**

Fig. (7.4)

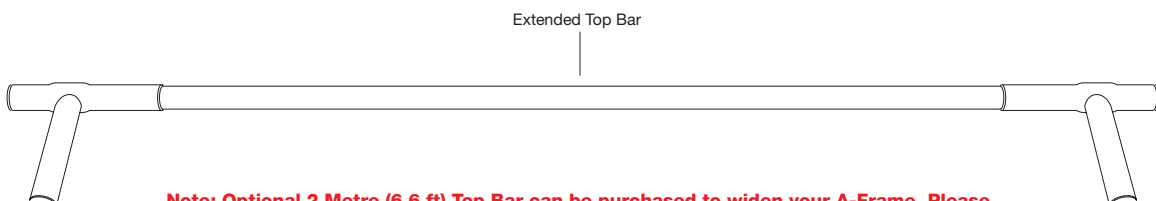

Note: Optional 2 Metre (6.6 ft) Top Bar can be purchased to widen your A-Frame. Please contact X-Pole or your local point-of-sale for further details.

LEADERS IN POLE & AERIAL FITNESS

Fig. (7.5)

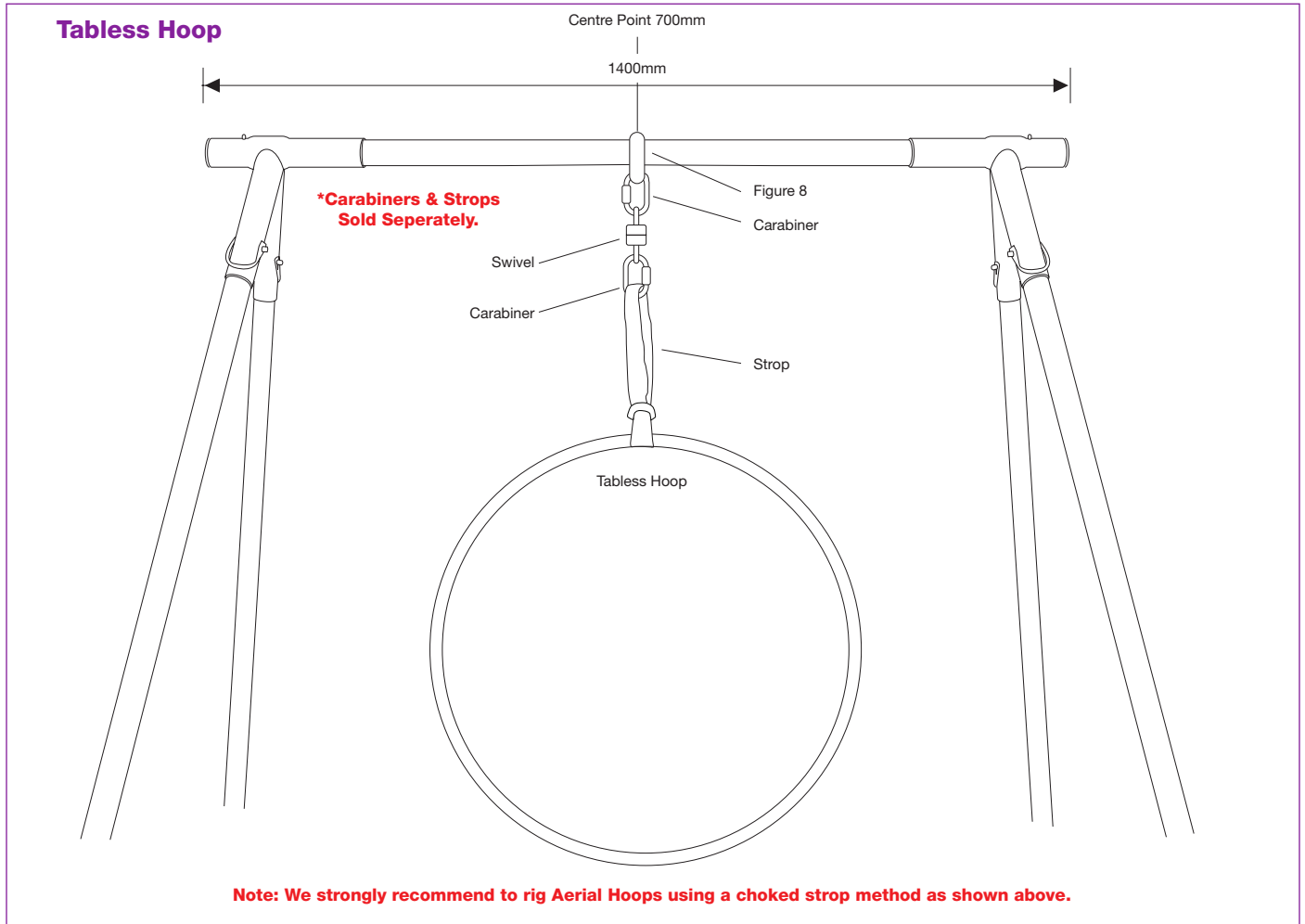

Fig. (7.6)

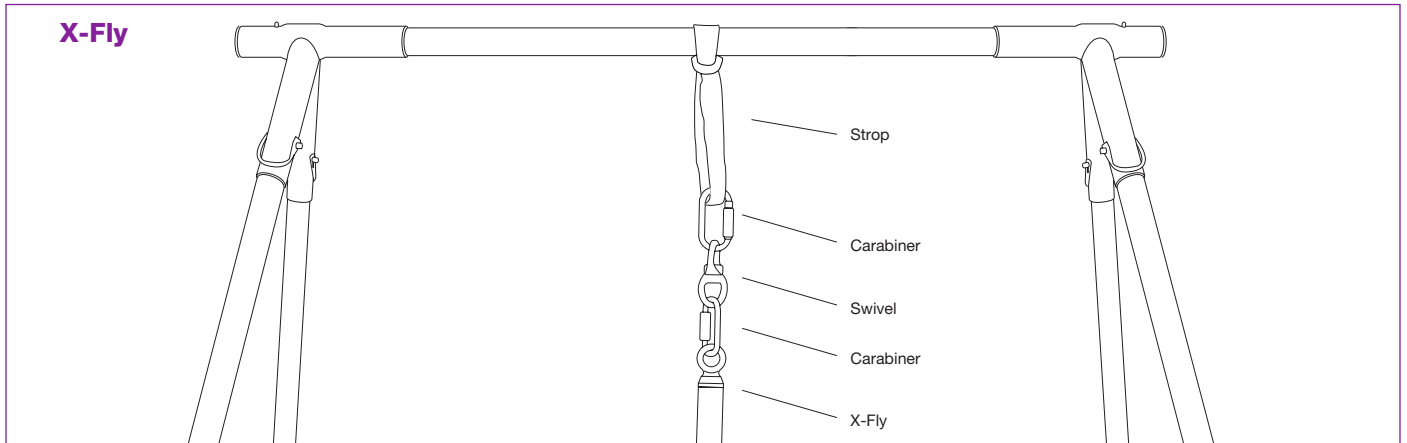

Fig. (7.7)

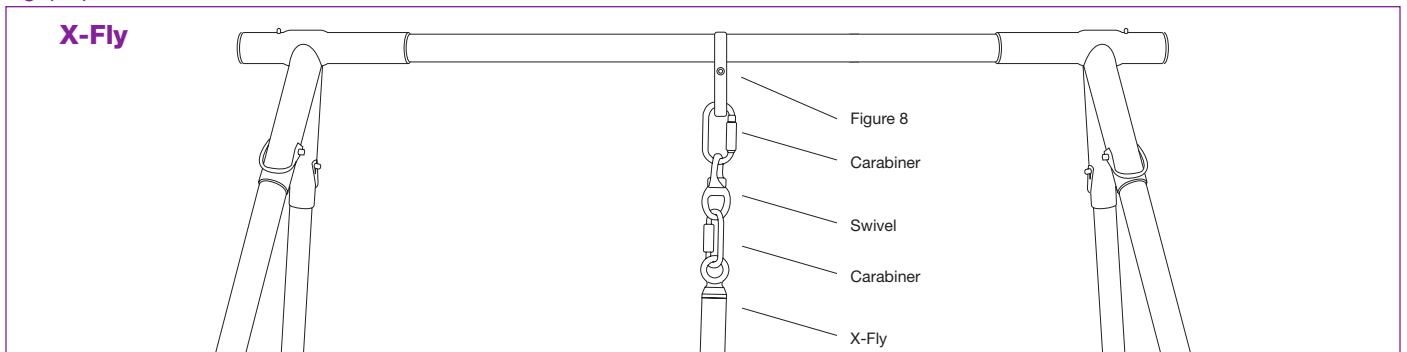
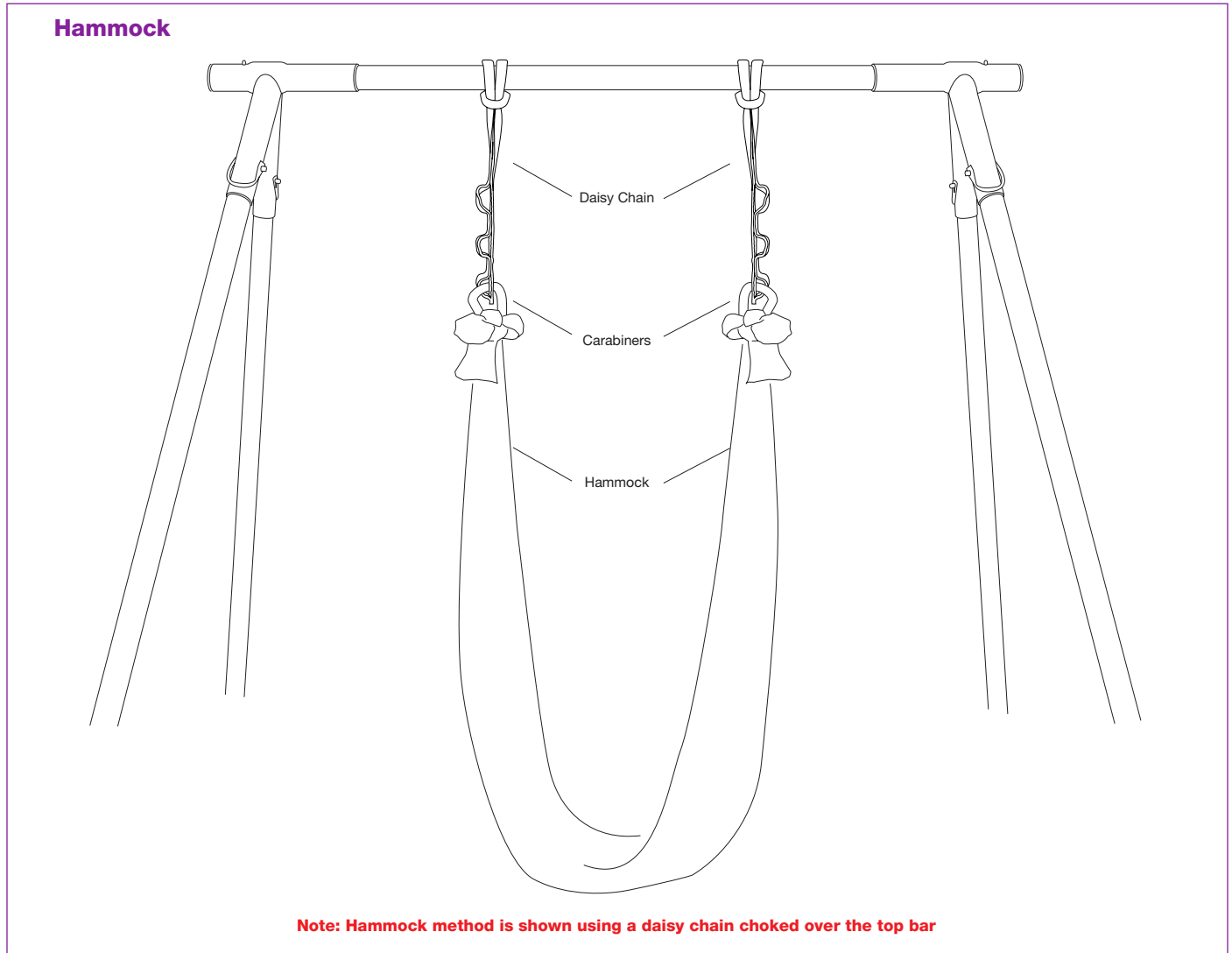

Fig. (7.8)



A-Frame Weight and Loadings Capacity

The X-POLE A frame is a light weight, portable, frame which has been designed for home and light studio use for Aerial Fitness.

The X-POLE A-Frame was not designed for professional performance use or dynamic drops.

The X-POLE A frame has been tested by an independant test house.

MBL (Minimum Breaking Load) = 700kg

WLL (Working Weight Load)

10:1 – 70kg/ 154lb

7:1 – 100kg/ 220lb

5:1 – 140kg / 309lb

No certification is possible as there are currently no international regulations for aerial fitness equipment to certify against.

The X-Pole A-Frame is being used in a low level training environment and so X-Pole uses a factor of 5:1.

Extension of Legs

When the A-Frame is delivered, the legs will be set at minimum height (for easy transportation).

Fig. (8.1)

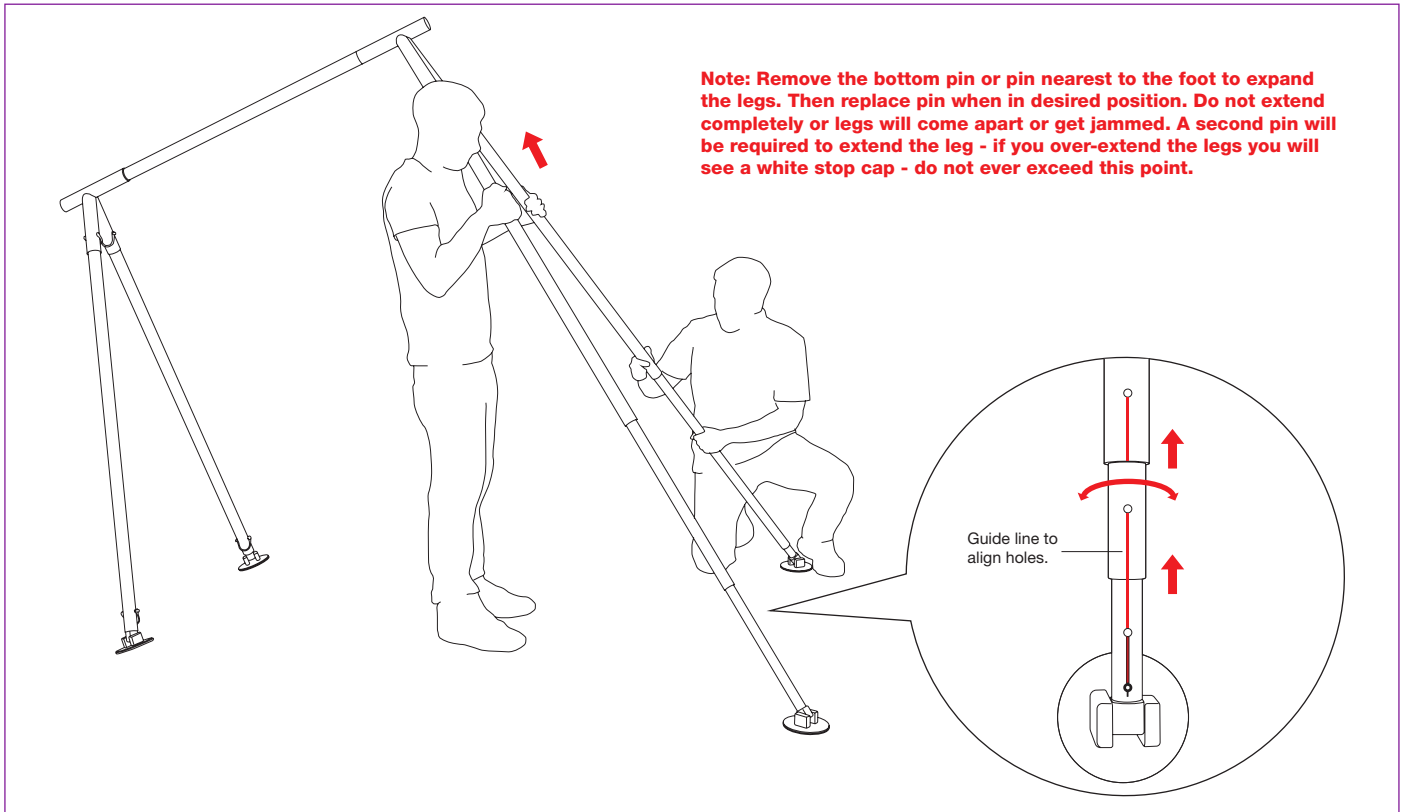
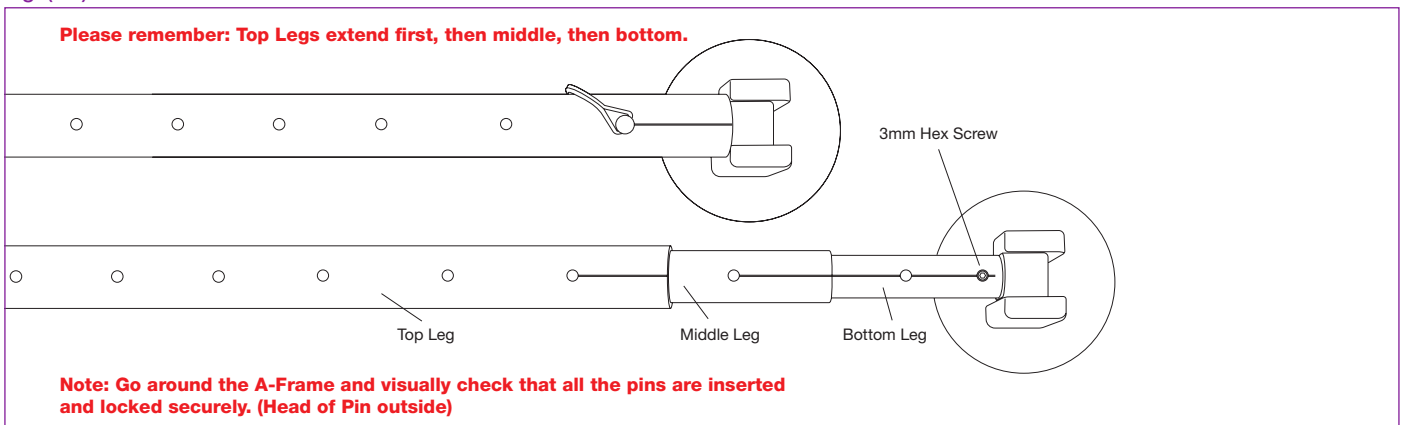

Fig. (8.2)



1. Remove both pins at one side of the A-Frame, as illustrated in figure: . With one person lifting – the legs can then be extended and pinned back into position (please ensure that the pins are positioned in the inside of the A-Frame & the legs are pinned back into position using the adjustment line to align).
2. Repeat this process on the opposite side. Please ensure both sides are level and extended evenly.
3. To lower the A-Frame, the reverse of this procedure must be repeated exactly the same on all four legs.
4. Final clip needs to be placed just above the feet on all four legs – this will later be used for further stabilisation using the sandbags.

Attachment Of The Straps

Fig. (9.1)

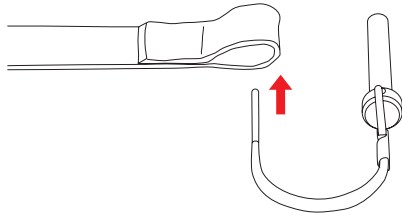

Insert loops into the strap opening

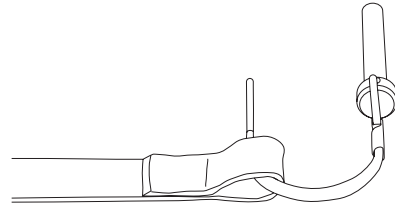

Pull the strap to the centre of the hook

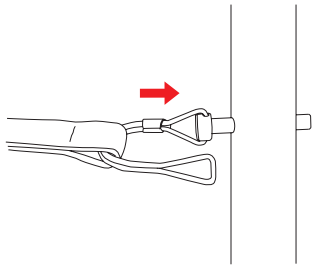

Insert pin through the leg hole at the desired position.

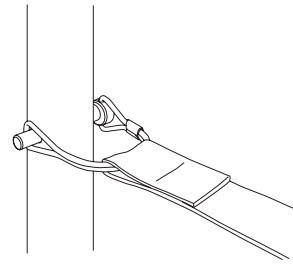

Clip the hook onto the pin.

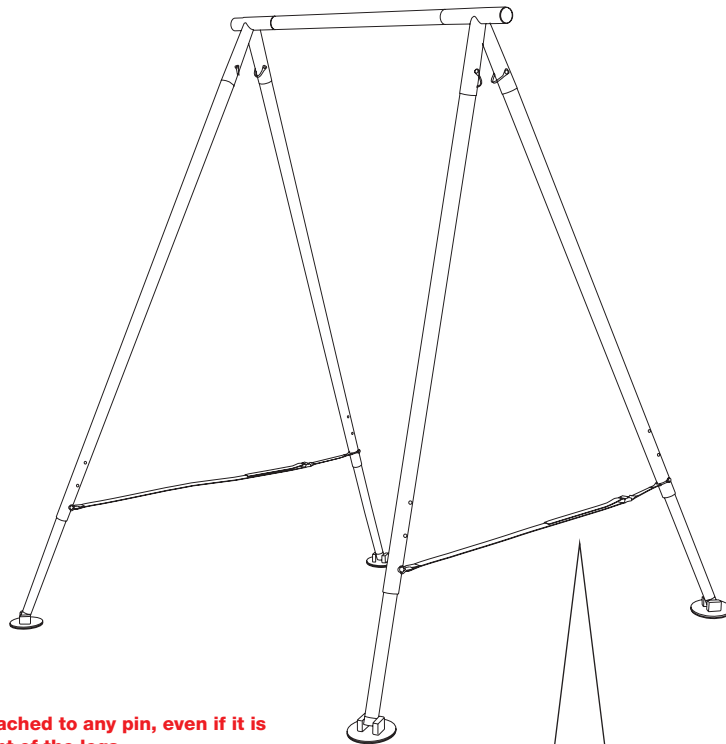

Note: The straps can be attached to any pin, even if it is being used to lock the height of the legs.

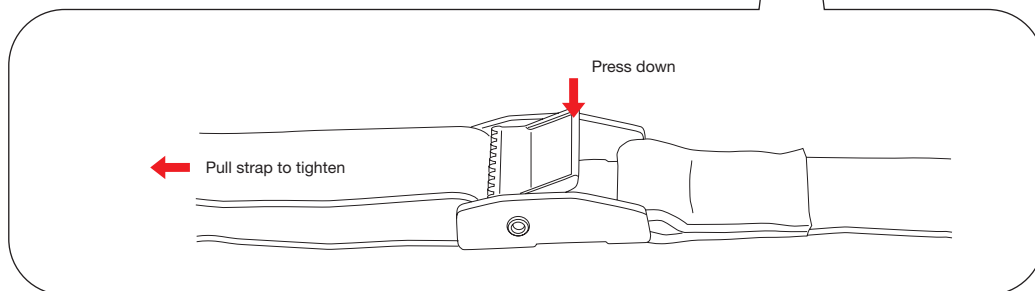

Filling & Attaching Sand Bag

Now that the A-FRAME has been fully assembled and the straps attached, it is now time to secure it in place using the additional sand/weight bags.

Fig. (10.1)

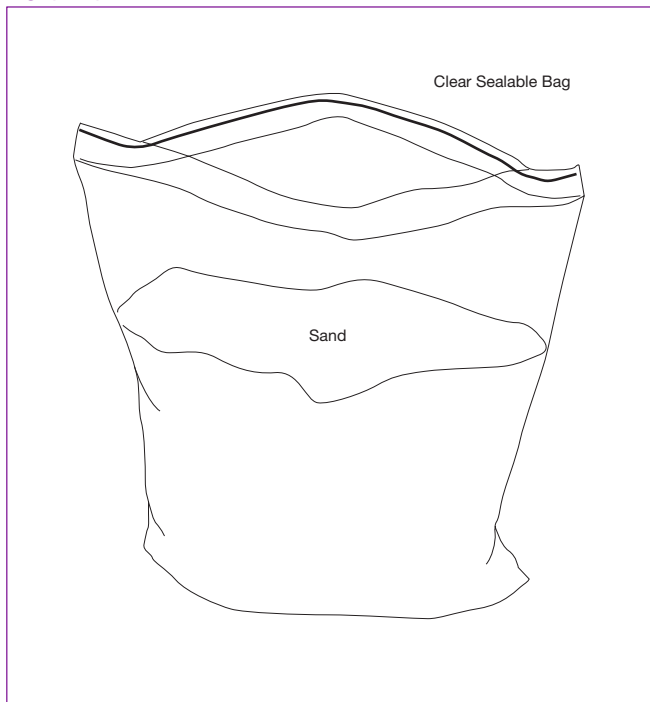
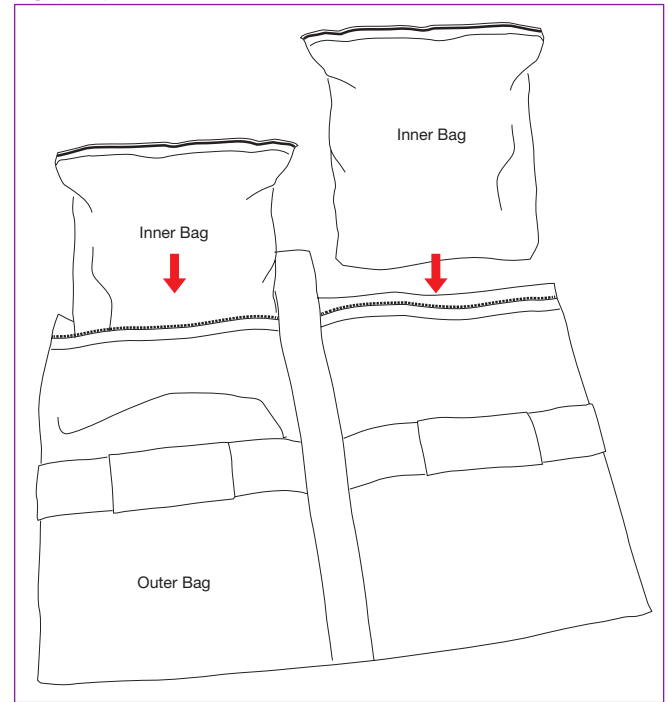

Fig. (10.2)



1. Firstly the inner Clear Sealable bags must be filled with sand/similar material - these hold around 5kg each.
2. The Clear Sealable bags must be then placed into the inner bags carefully.

3. The inner bags, once filled, must then be placed inside the outer bags. The inner bags are supplied to minimise risk of the contents spilling/leaking. Two inner bags must be placed inside a single outer.

Fig. (10.3)

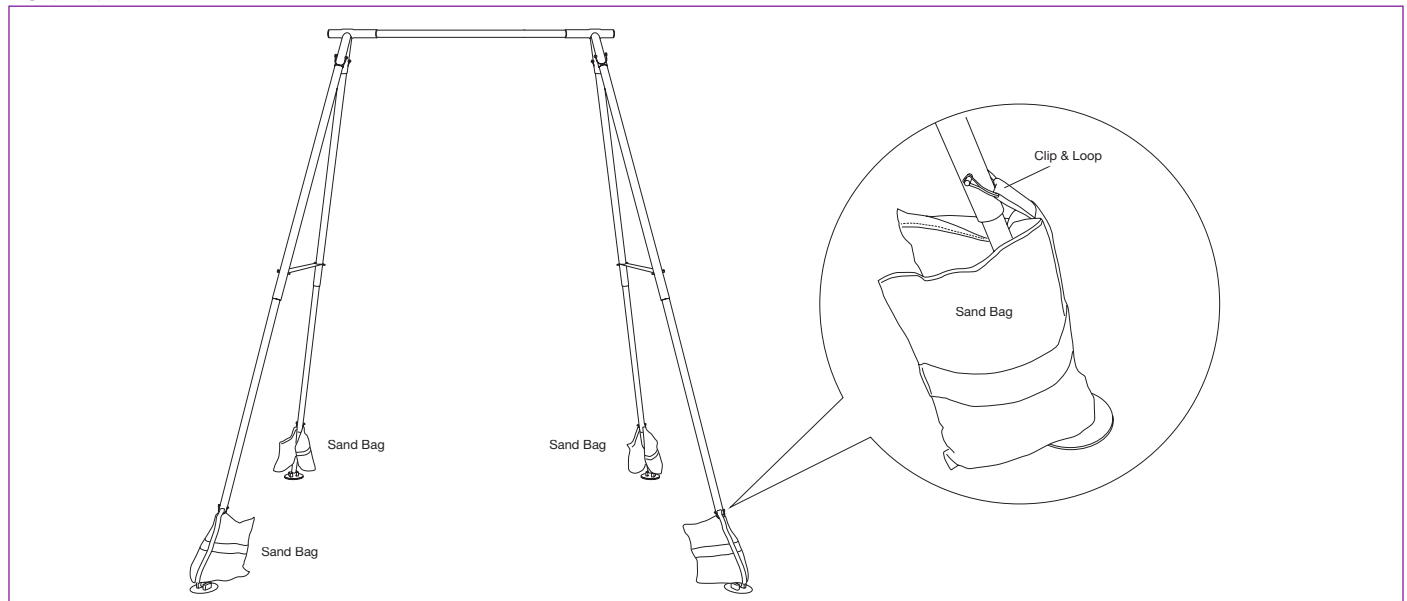

4. Now the weight bags can be attached to each leg of the A-FRAME. When attaching the weight bags using the clips, please make sure you place them through the loop on the sand bags. Now repeat for all remaining legs.

Dismantling The A-Frame

Fig. (11.1)

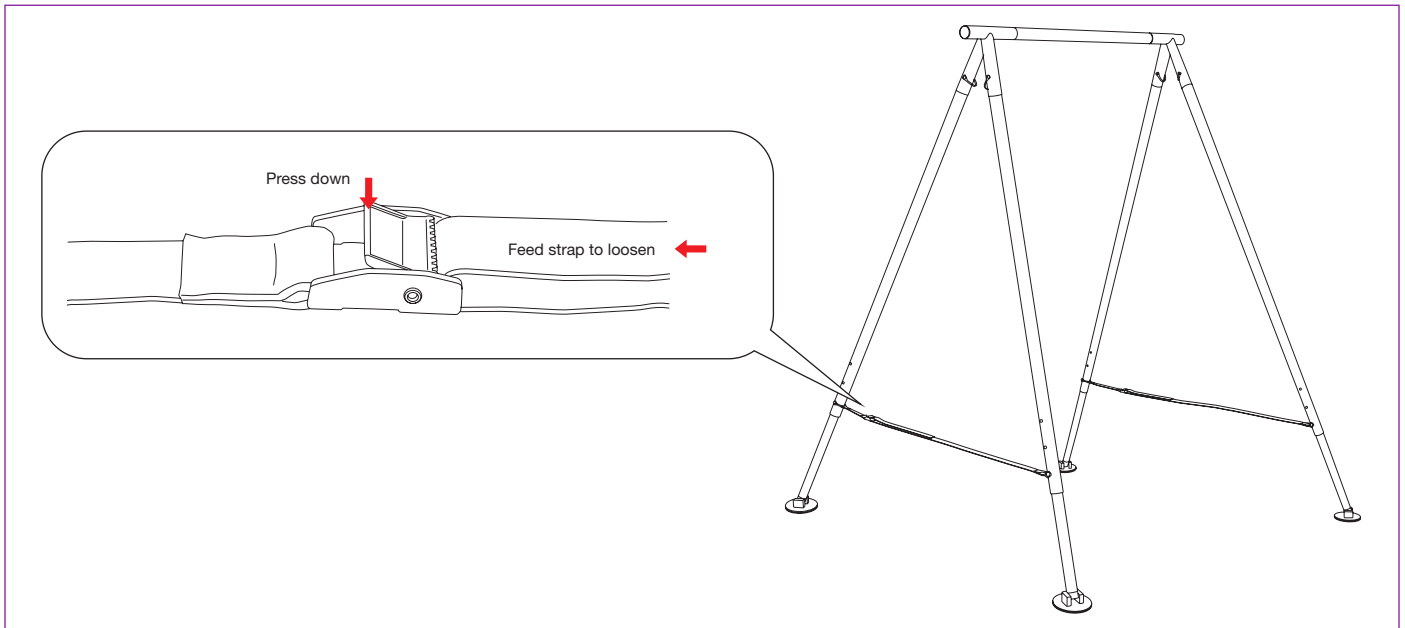

1. Remove the sand bags. 2. Remove the straps.

Fig. (11.2)

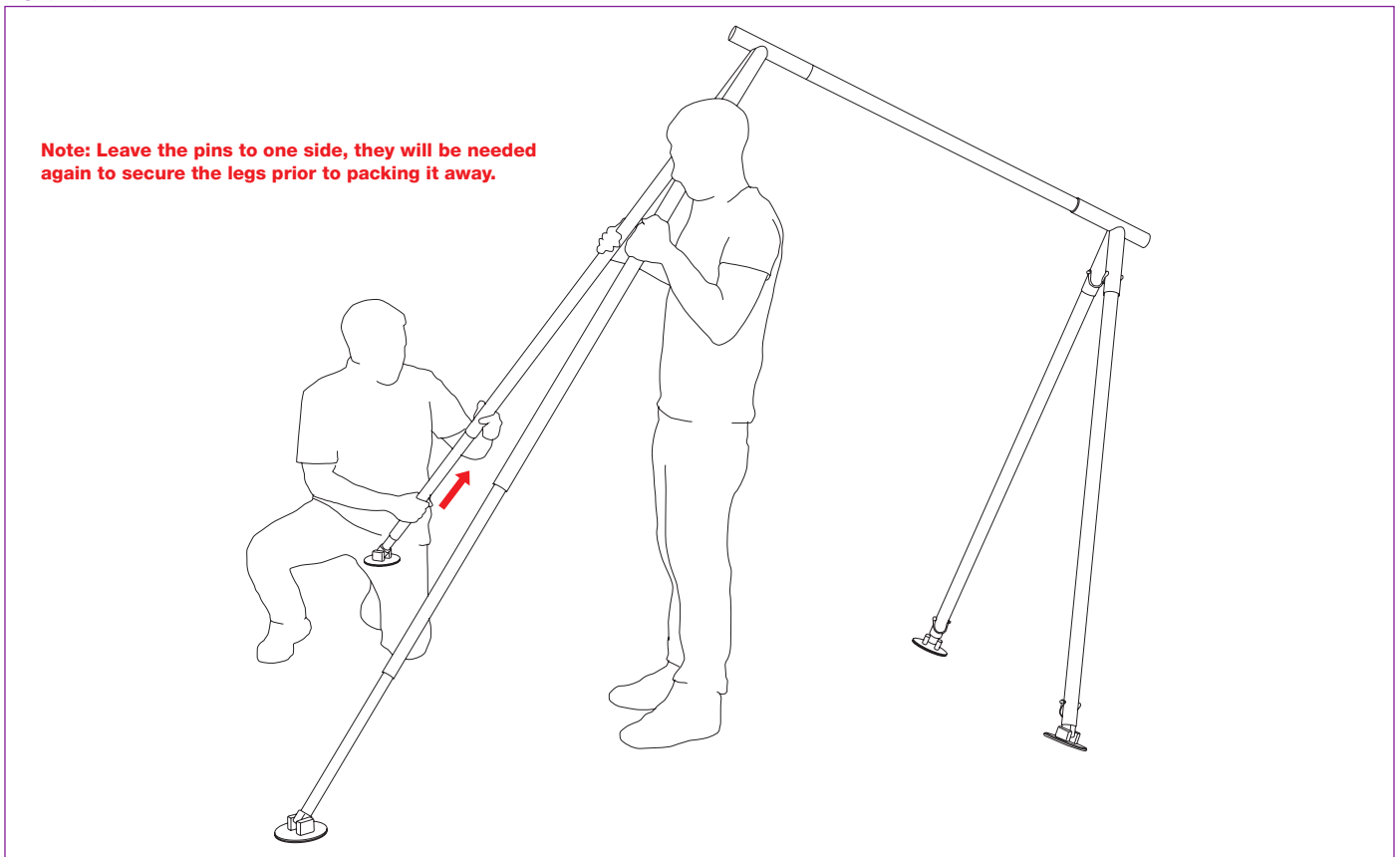

2. whilst the second person holds the legs. Slide both legs in.
3. Remove both pins at legs whilst another person holds the legs. Slide both legs in. Once the legs have been retracted on one side, lower this down so the feet are touching the floor, now repeat the same process for legs numbered.

Dismantling The A-Frame (Continued)

Fig. (12.1)

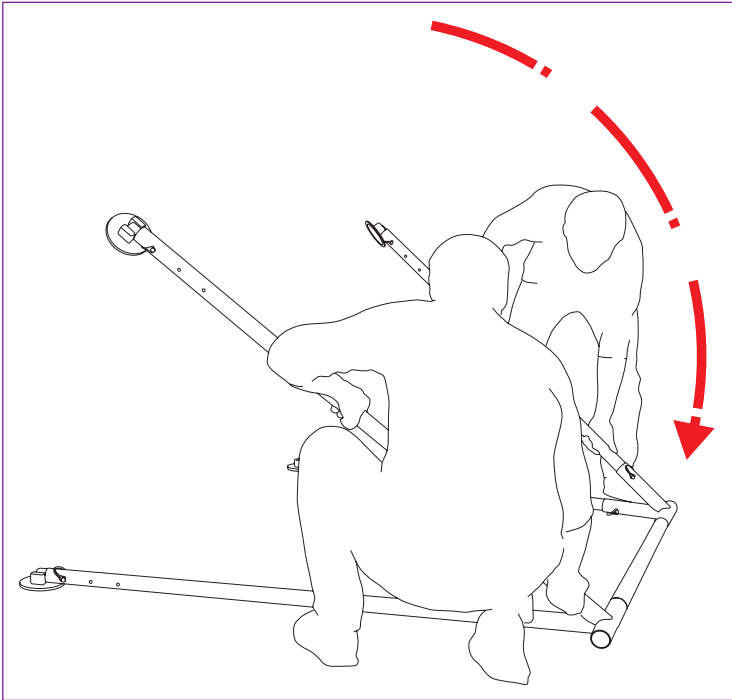

4. Now that the extended legs have been retracted, and your A-Frame is at the minimum height. Please make sure the pins above the feet are re-inserted to hold the legs in place when they are placed back into the carry cases.

5. Now lay the A-FRAME down so the top bar is touching the floor.

Fig. (12.2)

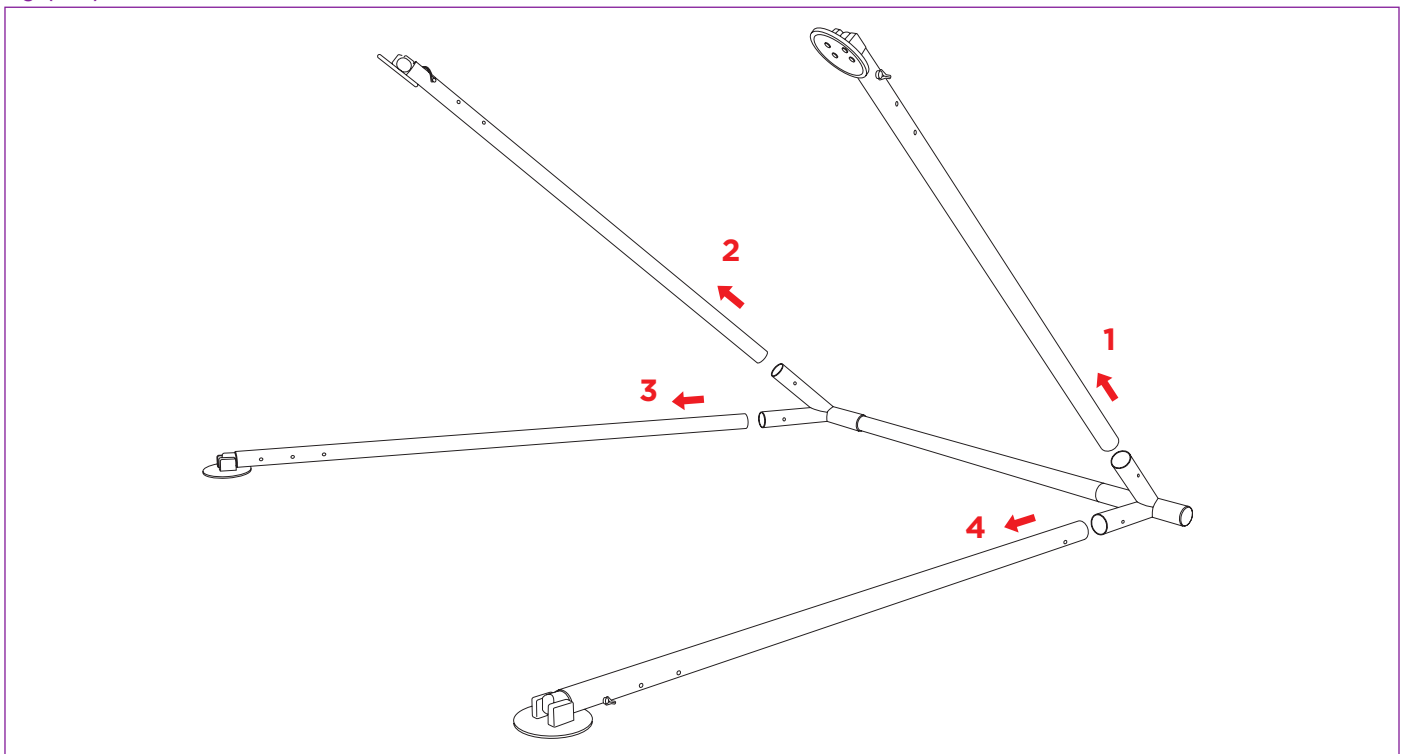

7. Remove the raised legs in the air first, then remove the legs touching the floor.

Dismantling The A-Frame (Continued)

Fig. (12.3)

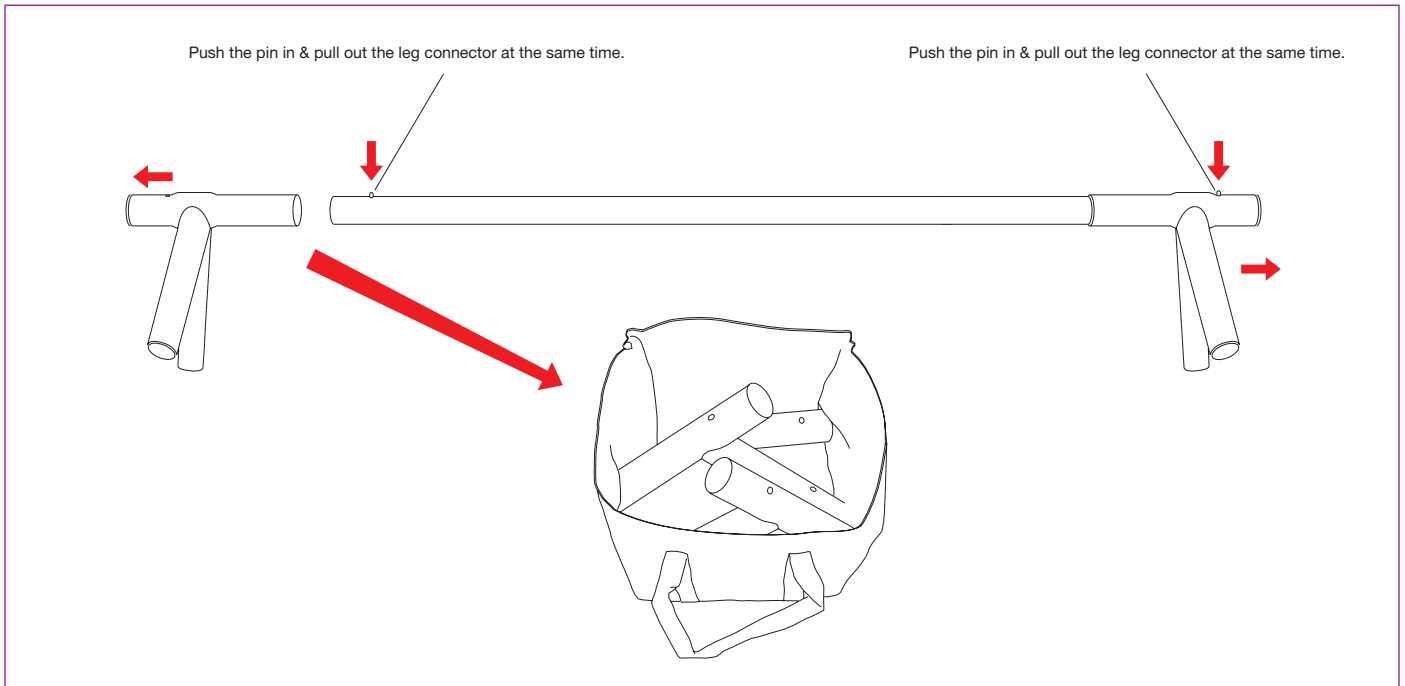

8. Remove connectors. (These are placed back in the square bag.)

Fig. (12.4)

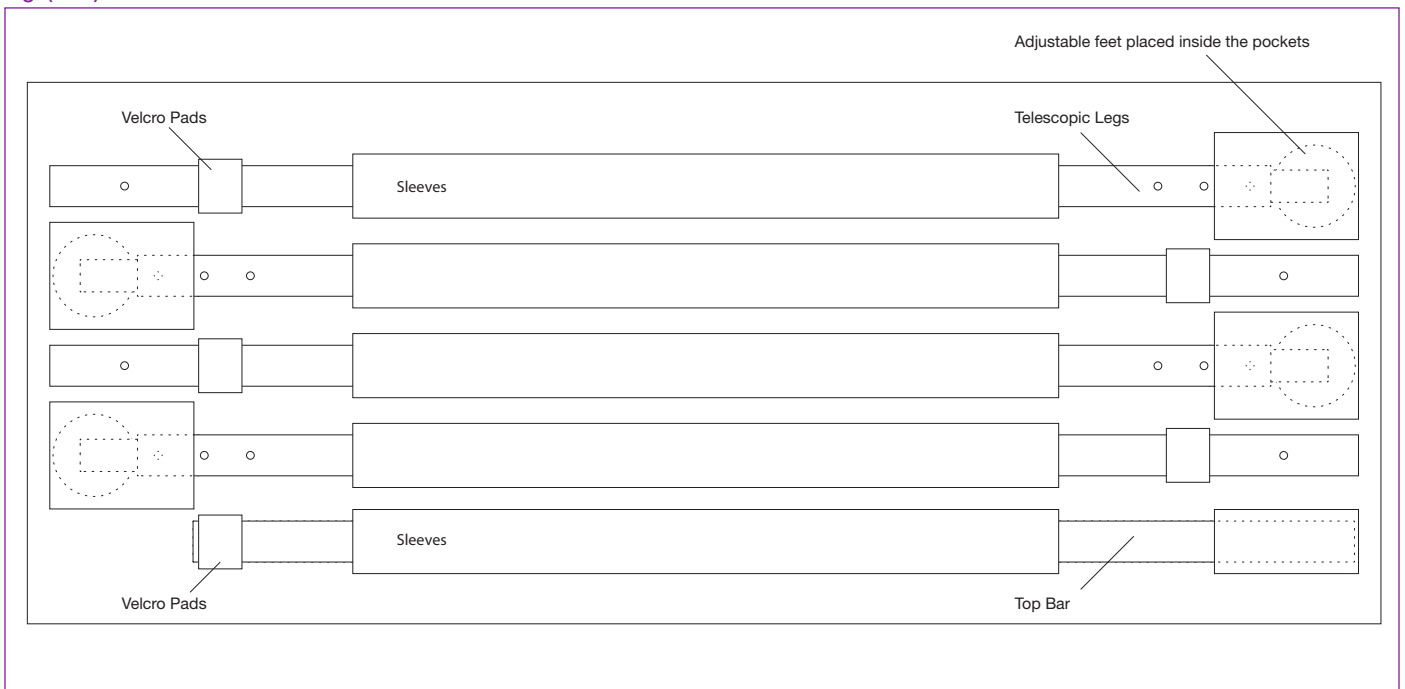

9. Place all the parts back in the bag.



CAUTION: Always store in a cool dry place. DO NOT! leave assembled outside.

X-POLE®

LEADERS IN POLE & AERIAL FITNESS

X-POLE UK & EUROPE

Email: sales@x-pole.co.uk

Tel: +44 (0) 208 449 4400

www.x-pole.co.uk

X-POLE USA

Email: info@xpoleus.com

Tel: +1 888 976 5387

www.xpoleus.com

X-POLE Australia

Email: sales@x-pole.com.au

Tel: +61 (0) 2 9589 2645

www.x-pole.com.au



X-POLE Korea

Email: xpolekorea@hanmail.net

Tel: +82 (0) 32 277 5882

www.xpolekorea.kr

X-POLE Asia

Email: sales@x-pole.asia

Tel: +86 (21) 6236 6090

www.xpolecn.com

X-POLE New Zealand

Email: sales@x-pole.co.nz

Tel: +64 (0) 9 528 0998

www.x-pole.co.nz

Warranty

This product has been manufactured and tested to the highest quality standards by X-POLE. This Limited Warranty offered by X-POLE covers defects in material or workmanship in new X-POLE products for a period of 6 months.

This warranty extends to the original purchaser only and is non-transferable. Only consumers purchasing X-POLE products from authorised X-POLE retailers or resellers or through the X-POLE website may obtain coverage under our limited warranties.

What is covered?

X-POLE warrants this product against defects in material or workmanship as follows:

X-POLE, at its own discretion, will replace at no charge, for parts only, replace any product or part of the product that proves defective because of improper workmanship and/or material, under normal installation, use, service and maintenance. If X-POLE is unable to provide a replacement and repair is not practical or cannot be made in a timely fashion, X-POLE may elect to refund the purchase price in exchange for the return of the product.

How Long Does The Coverage Last?

Our warranty periods are 6 MONTHS from the documented date of purchase, depending on the type of product and where it was purchased. This does not affect your statutory rights.

What Our Warranty Does Not Cover?

Our warranties do not cover any problem that is caused by:

- A.** Conditions, malfunctions or damage not resulting from defects in material or workmanship.
- B.** Conditions, malfunctions or damage resulting from (1) normal wear and tear, improper installation, improper maintenance, misuse, abuse, negligence, accident or alteration.
- C.** Accessories, connected materials and products, or related products not manufactured by X-POLE.
- D.** Defects from use, wear and tear, chipped edges from pole to pole contact or being dropped and anything outside of a pure manufacturing defect are not covered.